

SensoStar U

Ultrasonic heat meter for inline installation points



- Detection of back flow and air
- High temperature resistant for district heating
- Measuring cycle temperature, dynamic: 2 / 60 s
- Detachable calculator unit: 85 cm pulse cable length (2,85 m optional)
- Communication interfaces: wireless M-Bus;
wireless M-Bus + 3 pulse inputs;
M-Bus;
M-Bus + 3 pulse inputs;
1 pulse output;
2 pulse outputs

Архангельск (8182)63-90-72
Астрахань (8512)99-46-04
Барнаул (3852)73-04-60
Белгород (4722)40-23-64
Брянск (4832)59-03-52
Владивосток (423)249-28-31
Волгоград (844)278-03-48
Вологда (8172)26-41-59
Воронеж (473)204-51-73
Екатеринбург (343)384-55-89
Иваново (4932)77-34-06
Ижевск (3412)26-03-58
Иркутск (395)279-98-46

Казань (843)206-01-48
Калининград (4012)72-03-81
Калуга (4842)92-23-67
Кемерово (3842)65-04-62
Киров (8332)68-02-04
Краснодар (861)203-40-90
Красноярск (391)204-63-61
Курск (4712)77-13-04
Липецк (4742)52-20-81
Магнитогорск (3519)55-03-13
Москва (495)268-04-70
Мурманск (8152)59-64-93
Набережные Челны (8552)20-53-41
Нижний Новгород (831)429-08-12

Новокузнецк (3843)20-46-81
Новосибирск (383)227-86-73
Омск (3812)21-46-40
Орел (4862)44-53-42
Оренбург (3532)37-68-04
Пенза (8412)22-31-16
Пермь (342)205-81-47
Ростов-на-Дону (863)308-18-15
Рязань (4912)46-61-64
Самара (846)206-03-16
Санкт-Петербург (812)309-46-40
Саратов (845)249-38-78
Севастополь (8692)22-31-93
Симферополь (3652)67-13-56

Смоленск (4812)29-41-54
Сочи (862)225-72-31
Ставрополь (8652)20-65-13
Сургут (3462)77-98-35
Тверь (4822)63-31-35
Томск (3822)98-41-53
Тула (4872)74-02-29
Тюмень (3452)66-21-18
Ульяновск (8422)24-23-59
Уфа (347)229-48-12
Хабаровск (4212)92-98-04
Челябинск (351)202-03-61
Череповец (8202)49-02-64
Ярославль (4852)69-52-93

Киргизия (996)312-96-26-47

Казахстан (7273)495-231

Таджикистан (992)427-82-92-69

Measuring method		ultrasonic; time-of-flight								
Sizes	Nominal flow q_p	m ³ /h	0,6	1,5	1,5	2,5	3,5	3,5	6,0	10,0
	Low flow threshold	l/h	6	6	6	12	14	14	30	50
	Minimum flow q_i	l/h	12	12	12	25	28	28	60	100
	Maximum flow q_s	m ³ /h	1,2	3,0	3,0	5,0	7,0	7,0	12,0	20
	Pressure drop Δp at q_p	bar	0,03	0,21	0,04	0,12	0,21	0,21	0,20	0,11
	Pressure drop Δp at q_s	bar	0,13	0,85	0,17	0,46	0,89	0,89	0,80	0,43
	Nominal diameter	mm	DN 15	DN 15	DN 20	DN 20	DN 20	DN 25	DN 25	DN 40
	Thread	inch	G3/4B	G3/4B	G1B	G1B	G1B	G1 1/4B	G1 1/4B	G2B
	Length	mm	110	110	130	130	130	150	150; 260	200; 300
	Dynamic range q_i/q_p	-	1:50	1:125	1:125	1:100	1:125	1:125	1:100	1:100
	Accuracy class (MID)		class 2							
	Nominal pressure PN	bar	16							
	Temperature range medium heat	°C	15 – 90 15 – 130 high temperature (150; for maximal 2000 h) (optional)							
	Temperature range medium cooling (from q_p 1,5 to q_p 10)	°C	5 – 50							
	Temperature range medium heat / cooling	°C	15 – 90 heat 15 – 120 high temperature (optional) 5 – 50 cooling							
	Point of installation		outlet flow and inlet flow; can be set when the amount of energy is still \leq 10 kWh							
	Mounting position		any position							
	Protection class		IP65							
	Temperature range medium	°C	0 – 150 heat 0 – 50 cooling (from q_p 1,5 to q_p 10)							
	Ambient temperature in the field	°C	5 – 55 at 95 % relative humidity							
	Transport temperature	°C	-25 – 70 (for maximal 168 h)							
	Storage temperature	°C	-25 – 55							
	Temperature difference range $\Delta\theta$ heat	K	3 – 100							
	Temperature difference range $\Delta\theta$ cooling	K	-3 – -50							
	Minimum temp. difference $\Delta\theta$ heat	K	$> 0,05$							
	Minimum temperature difference $\Delta\theta$ cooling	K	$< -0,05$							
	Minimum temperature difference $\Delta\theta_{HC}$ heat / cooling	K	$> 0,5 / < -0,5$							
	Resolution temperature	°C	0,01							
	Measuring cycle temperature; dynamic	s	2 / 60; using a power pack: 2 s permanent							
	Measuring cycle flow	s	2							
	Display		LCD - 8 digits + special characters							
	Decimal places		up to 3 after comma							
	Units		MWh, kW, m ³ , m ³ /h (kWh, GJ, MMBTU, Gcal); unit of energy can be set when the amount of energy is still \leq 10 kWh							

Interfaces		optical interface (M-Bus protocol); optional: wireless M-Bus; wireless M-Bus + 3 pulse inputs; M-Bus; M-Bus + 3 pulse inputs; 1 pulse output; 2 pulse outputs
Power supply		exchangeable 3 V lithium battery; all types prepared for 3 V power pack (input voltage 230 V / 24 V)
Estimated lifetime	years	10 (no option: 1 pulse output); 6+1
Data storage		nonvolatile memory
Reading dates		selectable yearly reading date; 15 monthly and semimonthly values: via display or wireless M-Bus (compact mode); 24 monthly and semimonthly values: via optical interface or M-Bus
2 tariff registers		can be set individually; adding up energy or time
Storage of maximum values		flow, power and temperatures (inlet, outlet, $\Delta\theta$), plus the respective maximum values of the last 15 months
Protection class		IP65
CE		yes
EMC		EN 1434
Platinum precision resistor		Pt 1000
Diameter	mm	5; 5,2; 6; AGFW 27,5; 38; needle sensor 3,5 x 75
Length of cable	m	1,5; 3; 6
Installation		asymmetrical; symmetrical

Calculator housing (H x W x D) mm 75 x 110 x 34,5

Dimensions meter

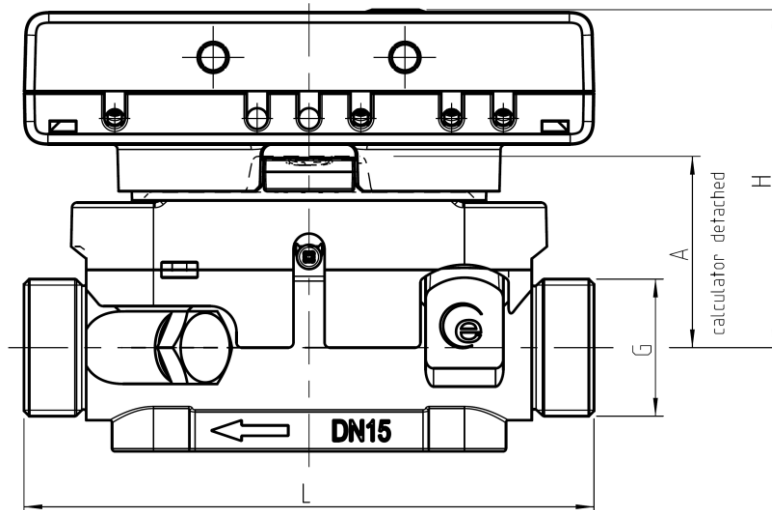

Qp (m ³ /h)	Nominal diameter	G (")	L (mm)	H (mm)	A (mm)	Weight (basic version in kg)
0,6	DN 15	G3/4B	110	65	37	0,720
1,5	DN 15	G3/4B	110	65	37	0,720
1,5	DN 20	G1B	130	65	37	0,770
2,5	DN 20	G1B	130	65	37	0,770
3,5	DN 20	G1B	130	65	37	0,770
3,5	DN 25	G1 1/4B	150	65	37	0,930
6,0	DN 25	G1 1/4B	150	67,5	39,5	0,930
6,0	DN 25	G1 1/4B	260	67,5	39,5	1,200
10,0	DN 40	G2B	200	73	45	1,580
10,0	DN 40	G2B	300	73	45	2,050

pressure drop SensoStar U

pressure drop [mbar]

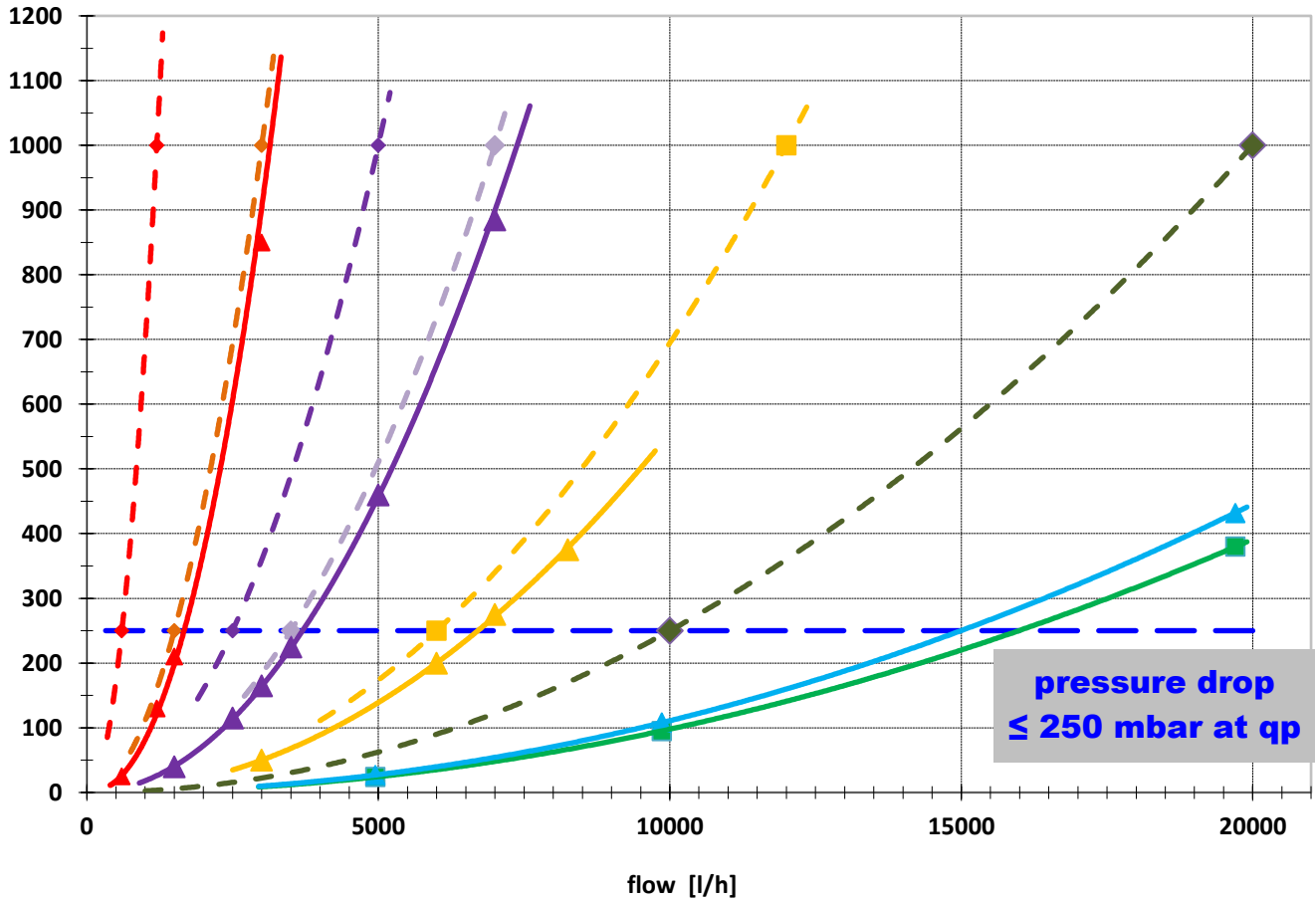

- ◆ EN1434 Limit qp0,6
- ◆ EN1434 Limit qp1,5
- ◆ EN1434 Limit qp2,5
- ◆ EN1434 Limit qp3,5
- EN1434 Limit qp6,0
- ◆ EN 1434 Limit qp10
- ▲ pressure drop qp 0,6 / 1,5
- ▲ pressure drop qp 2,5 / 3,5 / 1,5 (DN20)
- ▲ pressure drop qp 6,0
- pressure drop qp 10 200 mm
- ▲ pressure drop qp 10 300 mm
- - EN 1434

По вопросам продажи и поддержки обращайтесь:

Архангельск (8182)63-90-72
Астрахань (8512)99-46-04
Барнаул (3852)73-04-60
Белгород (4722)40-23-64
Брянск (4832)59-03-52
Владивосток (423)249-28-31
Волгоград (844)278-03-48
Вологда (8172)26-41-59
Воронеж (473)204-51-73
Екатеринбург (343)384-55-89
Иваново (4932)77-34-06
Ижевск (3412)26-03-58
Иркутск (395)279-98-46

Казань (843)206-01-48
Калининград (4012)72-03-81
Калуга (4842)92-23-67
Кемерово (3842)65-04-62
Киров (8332)68-02-04
Краснодар (861)203-40-90
Красноярск (391)204-63-61
Курск (4712)77-13-04
Липецк (4742)52-20-81
Магнитогорск (3519)55-03-13
Москва (495)268-04-70
Мурманск (8152)59-64-93
Набережные Челны (8552)20-53-41
Нижний Новгород (831)429-08-12

Новокузнецк (3843)20-46-81
Новосибирск (383)227-86-73
Омск (3812)21-46-40
Орел (4862)44-53-42
Оренбург (3532)37-68-04
Пенза (8412)22-31-16
Пермь (342)205-81-47
Ростов-на-Дону (863)308-18-15
Рязань (4912)46-61-64
Самара (846)206-03-16
Санкт-Петербург (812)309-46-40
Саратов (845)249-38-78
Севастополь (8692)22-31-93
Симферополь (3652)67-13-56

Смоленск (4812)29-41-54
Сочи (862)225-72-31
Ставрополь (8652)20-65-13
Сургут (3462)77-98-35
Тверь (4822)63-31-35
Томск (3822)98-41-53
Тула (4872)74-02-29
Тюмень (3452)66-21-18
Ульяновск (8422)24-23-59
Уфа (347)229-48-12
Хабаровск (4212)92-98-04
Челябинск (351)202-03-61
Череповец (8202)49-02-64
Ярославль (4852)69-52-93

Киргизия (996)312-96-26-47

Казахстан (7273)495-231

Таджикистан (992)427-82-92-69

Единый адрес для всех регионов: egs@nt-rt.ru || www.engelmann.nt-rt.ru